

10 INCH AWNING STEEL	LEFT	13.13.00.243
	RIGHT	13.13.00.244
10 INCH AWNING SST	LEFT	13.13.00.543
	RIGHT	13.13.00.544

ONE ARM ASSEMBLY AND ONE TRACK ASSEMBLY  
REQUIRED TO MAKE A COMPLETE HINGE.

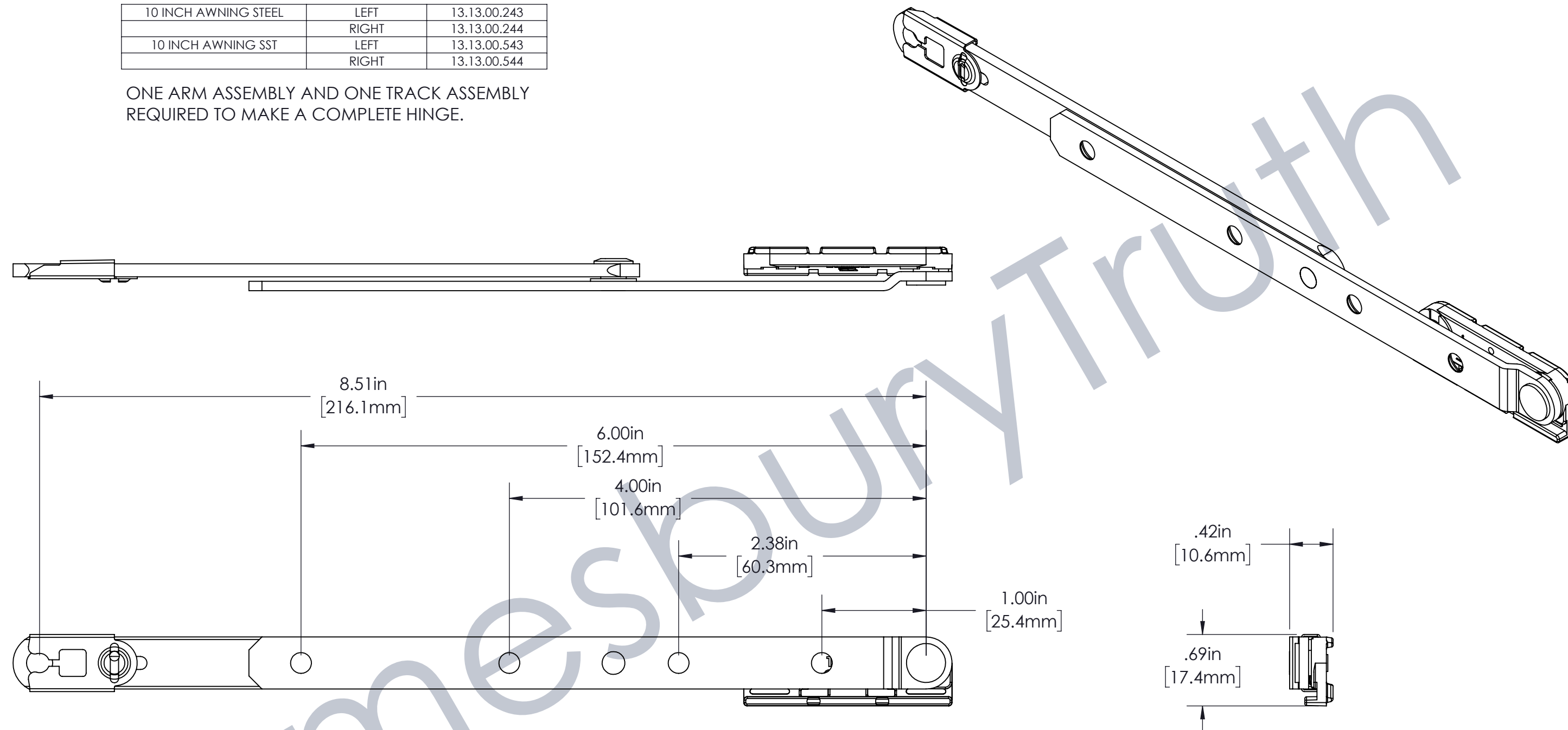

RECOMMENDED SCREWS:  
(P/N 19110.XX) NO. 7 X .750 PHILLIPS FLAT HEAD SHEET METAL SCREWS (STEEL)  
(P/N 19105.XX) NO. 7 X .750 PHILLIPS FLAT HEAD SHEET METAL SCREWS (STAINLESS STEEL)

FOR USE WITH TRACK ON PVC:  
NO. 7 X .750 PHILLIPS FLAD HEAD UNDERCUT SHEET METAL SCREWS.  
(NOT AVAILABLE FROM TRUTH, QUANTITIES DEPEND ON HINGE USED)  
SEE TRUTH TIP NO. 5 & 6

CUSTOMER PAGE

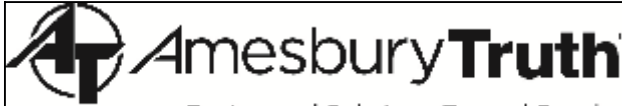
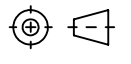
 <b>Amesbury Truth</b> Engineered Solutions. Trusted Results.	INTERPRET PER: ASME Y14.5M-2009 UNITS: INCH	DRAWING TITLE: 13.13.00.243 10" KD AWNING ARM, STEEL
	THIRD ANGLE PROJECTION 	SCALE: 1:1 DRAWING #: 13.13.00.243 CUSTOMER PA